

Steeler Slotted Stud™

DESCRIPTION

Steeler Slotted Stud™ is one component of the Steeler Slotted Stud Head-of-Wall Deflection System consisting of the addition of Steeler Deep Leg Track attached by screws penetrating the leg of the track and freely floating in the slot at the top of the Steeler Slotted Stud.

The Steeler Slotted Stud has two 2-1/4" slots (one in each flange) at the head of the stud which allows for up to a full 2" vertical deflection. Since the deflection slot is in the stud rather than the track (such as conventional slotted track), the stud is secured at its actual location anywhere along the solid track. Steeler Slotted Stud is available in web dimensions from 2-1/2" – 12" and in gauges from 30 mil – 68 mil thicknesses.

MATERIALS

Steeler Slotted Studs section is fabricated from 25 to 12 gauge hot dipped galvanized steel conforming to ASTM A653 or equal.

COLOR CODE

Traditional	Elite
24 Gauge – Orange	30ED Gauge – Red and Blue
22 Gauge – Black	33ES Gauge – Purple
20D Gauge – Pink	43ES Gauge – Brown
20S Gauge – White	54ES Gauge – Light Blue
18 Gauge – Yellow	
16 Gauge – Green	
14 Gauge – Orange	
12 Gauge – Red	
10 Gauge – Blue	

ASTM & CODE STANDARDS

- IBC 2009/2012
 - AISI NASPEC 2007
 - Meets or exceeds:
 - ASTM C754 & ASTM C645
 - ASTM E119 & E90
 - ASTM A370
 - ASTM A1003
 - ASTM C1513
- Please reference Steeler ICC-ES Report ESR-2054 for further information. Available for download at www.steeler.com/technicalinfo.php

MANUFACTURER CONTACT INFORMATION

Seattle Plant | 10023 MLK Jr. Way S. Seattle, WA 98178 | P: 206-725-2500

Newark Plant | 6851 Smith Ave. Newark, CA 94560 | P: 510-505-9574

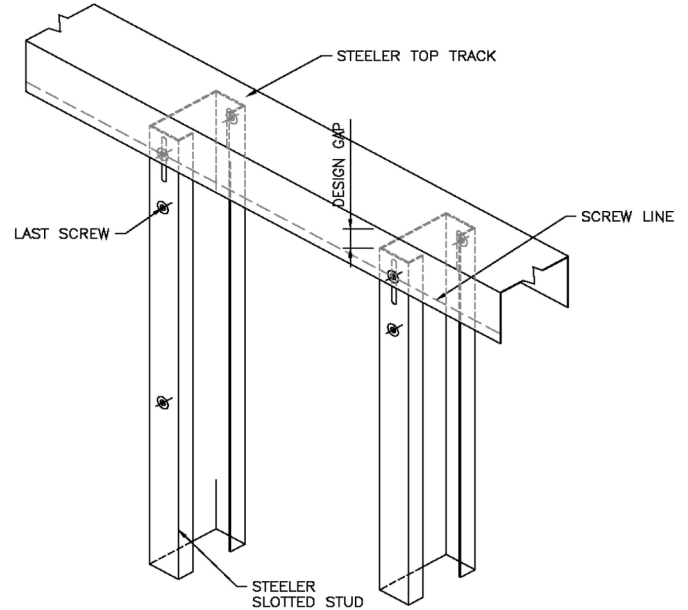

CLASSIFICATION

Steeler Slotted Stud has been cycle tested for 500 cycles in accordance with the 4th Edition of ANSI/UL 2079 (ASTM E1966) and is U.L. Classified for both the United States & Canada as Light Gauge Framing in various U.L. Head-Of-Wall Joint Systems.

- California State Fire Marshall Listed
- U.L. Classified XHLI.R21503 U.L. Classified for Canada XHLI7.R21503



UL® Head of Wall Systems Files (Steeler Slotted Stud™)

UL File Number:	Fire Rating:	Movement Class & Capabilities:
HW-D-0016	1 & 2 Hour Fire Rating	Classes II & III, 25% Compression
HW-D-0020	1 & 2 Hour Fire Rating	Class II, 25% Compression or Extension
HW-D-0021	1 & 2 Hour Fire Rating	Class II, 18.75% Compression or Extension
HW-D-0029	1 & 2 Hour Fire Rating	Class II, 25% Compression or Extension
HW-D-0032	2 Hour Fire Rating	Class II, 50% Compression or Extension
HW-D-0033	2 Hour Fire Rating	Class II, 50% Compression or Extension
HW-D-0034	1 & 2 Hour Fire Rating	Class II, 25% Compression or Extension
HW-D-0037	2 Hour Fire Rating	Class II, 18.75% Compression or Extension
HW-D-0048	1 & 2 Hour Fire Rating	Class II, 33% Compression or Extension
HW-D-0049	1 & 2 Hour Fire Rating	Class II, 50% Compression or Extension